

Art.: 3059

Válvula de esfera para manguera / Bibcock ball valve

Características	Features
1. Válvula de esfera para conexión manguera.	1. Bibcock ball valve to hose connection.
2. Paso total.	2. Full bore.
3. Construcción en latón s/ UNE-EN 12165 cromado.	3. Brass construction acc/ UNE-EN 12165 chrome plated.
4. Entrada rosca gas (BSP) macho s/ ISO 228/1.	4. Gas (BSP) threaded male inlet acc/ ISO 228/1.
5. Salida racor de dos piezas con difusor para conectar manguera.	5. Fitting two-piece with diffuser for connect hose.
6. Accionamiento mediante palanca de acero.	6. Working by means of steel lever handle.
7. Eje no eyectable.	7. Non ejectable stem.
8. Asientos PTFE.	8. PTFE Seats.
9. Temperatura de trabajo desde -20°C a 100°C.	9. Working temperature from -20°C to 100°C.
10. Presión máxima de trabajo 16 bar (PN 16).	10. Maximum working pressure 16 bar (PN 16).
11. Dispositivo para bloqueo en abierto y cerrado.	11. Lockable in open and close position.

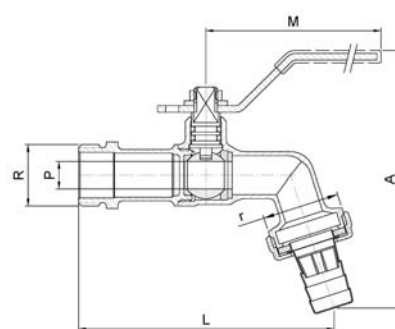
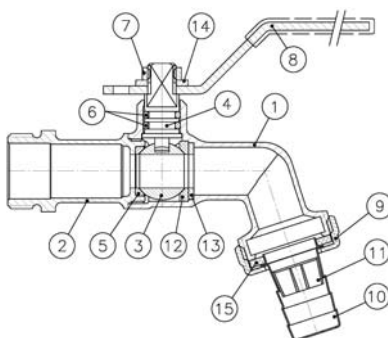

Nº	Denominación / Name	Material	Acabado Sup. / Surface Treatment
1	Cuerpo / Body	Latón / Brass (CW617N)	Granallado+Cromado / Peened+Chromed
2	Tapa / Cap	Latón / Brass (CW617N)	Granallado+Cromado / Peened+Chromed
3	Esfera / Ball	Latón / Brass (CW617N)	Cromado / Chrome plated
4	Eje / Stem	Latón / Brass (CW617N)	Cromado / Chrome plated
5	Asiento / Ball seat	PTFE	-
6	Junta tórica / O-ring	NBR	-
7	Tuerca / Nut	Acero Inox. / S.Steel AISI 304	-
8	Maneta / Handle	Acero / Steel	Dacromet / Dacromet
9	Tuerca / Nut	Latón / Brass (CW617N)	Granallado+Cromado / Peened+Chromed
10	Conexión / Hose Connection	*Latón - Ac. Inox. / Brass - SS	Cromado / Chrome plated
11	Difusor / Diffuser	Nylon	-
12	Asiento / Ball seat	PTFE	-
13	Anillo asiento / Seat ring	Latón / Brass (CW617N)	-
14	Arandela / Grower Washer	Acero Inox. / S.Steel AISI 304	-
15	Junta / Joint	NBR	-

*Conexión en Acero Inox. AISI 201 para 3059 04 y 3059 05, Latón CW617N para 3059 06 / Hose connection in SS AISI 201 for 3059 04 & 3059 05, Brass CW617N for 3059 06.

Ref.	Medida / Size		Dimensiones / Dimensions (mm)				Peso / Weight (Kg)
	R x r	P	A	L	M		
3059 04	1/2" x 3/4"	10	88	85	84	0,147	
3059 05	3/4" x 1"	12	95	95	84	0,204	
3059 06	1" x 1"	15	112	119	98	0,308	